

L500 White

High intensity obstruction light

High intensity Obstruction light for day and night time marking of structures that present a hazard to aviation. White flashing in day and white flashing in night mode. Incorporates the benefits of advanced LED, optical and system control technologies to meet the most demanding applications.



KEY FEATURES

- Five year warranty
- Housing based on 30 years of experience offshore product design experience
- Lightweight and easy to install
- Extremely low wind factor
- Integrated design with built-in photocell and monitoring – no additional power supply enclosures required
- Built in GPS for synchronisation
- No maintenance required over service life
- Orga optical design produces highly accurate and uniform narrow light beam
- Optional Integrated automatic flash synchronisation between lights
- Extremely low power consumption
- Constant power draw for white variants – eliminates high peak power demands especially important when running from UPS
- 15 year field proven power supply technology
- Long life power supply to match LED life, does not use electrolytic capacitors

STANDARDS/CERTIFICATION

- Certified to ICAO Annex 14 Volume 1, Eighth Edition, July 2018, Chapter 6, High Intensity Type A obstacle light

PERFORMANCE CHARACTERISTICS

- Flashing: see table
- Effective intensity: see table
- Horizontal beam pattern: >120 degrees
- Vertical beam pattern: 3° minimum

ELECTRICAL CHARACTERISTICS

- Operating voltage: 120-240Vac nominal 50-60Hz
- Power factor: >0.9 in day intensity mode
- Power consumption: see table
- Power consumption heater: standard 95w
- Overvoltage protection: Class III according to IEC61643-1

PHYSICAL CHARACTERISTICS

- Dimensions: L x W x H: see drawing
- Weight: 33 KG
- Design degree of protection: IP65
- Operating temperature range: -40°C/+45 °C
- Shipping information: 666 x 666 x 635 mm
- Supplied with pre-mounted Orga cable for easy installation and high reliability ready for use
- Cable bending radius static: 7x cable diameter
- Outer cable diameter: Ø12.5 +/- 0.5 mm
- Cable weight: 260 g/m
- Level indicators for correct mounting

SYSTEM DESIGN, CONTROL AND MONITORING

- Use as a stand-alone light, or in a multiple light system with an Orga CIP controller
- Optional Orga CIP controller facilities provides control interfaces for:
 - “smart switch” aircraft detection input
 - Visibility condition variable intensity input
 - Visibility condition variable intensity input; intensity steps 30% and 10%
 - Remote photocell control input/override



L500 White

High intensity obstruction light

Product	Light performance			Additional information			
Type	Light performance			Power consumption (W) @ 20 °C			Standard
	Day	Tw	Night	Day	Tw	Night	
L500-63A-2S-G	200.000 cd 40 fpm White	20.000 cd 40 fpm White	2.000 cd 40 FPM White	81 W	14 W	11 W	
L500-63A-2S-60-G	200.000 cd 60 fpm White	20.000 cd 60 fpm White	2.000 cd 60 FPM White	120 W	17 W	11 W	



L500 White

High intensity obstruction light

FRONT VIEW

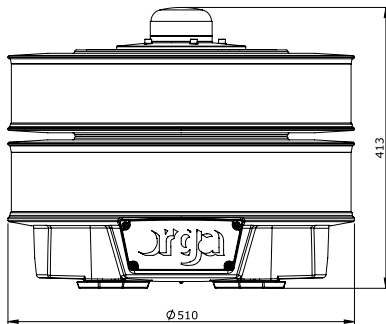

RIGHT VIEW

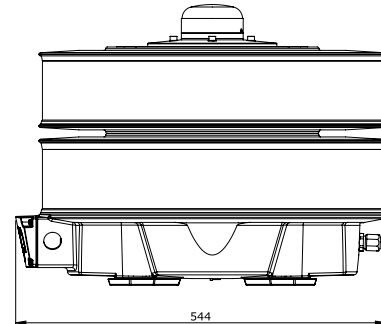

BOTTOM VIEW

