

TOP VIEW

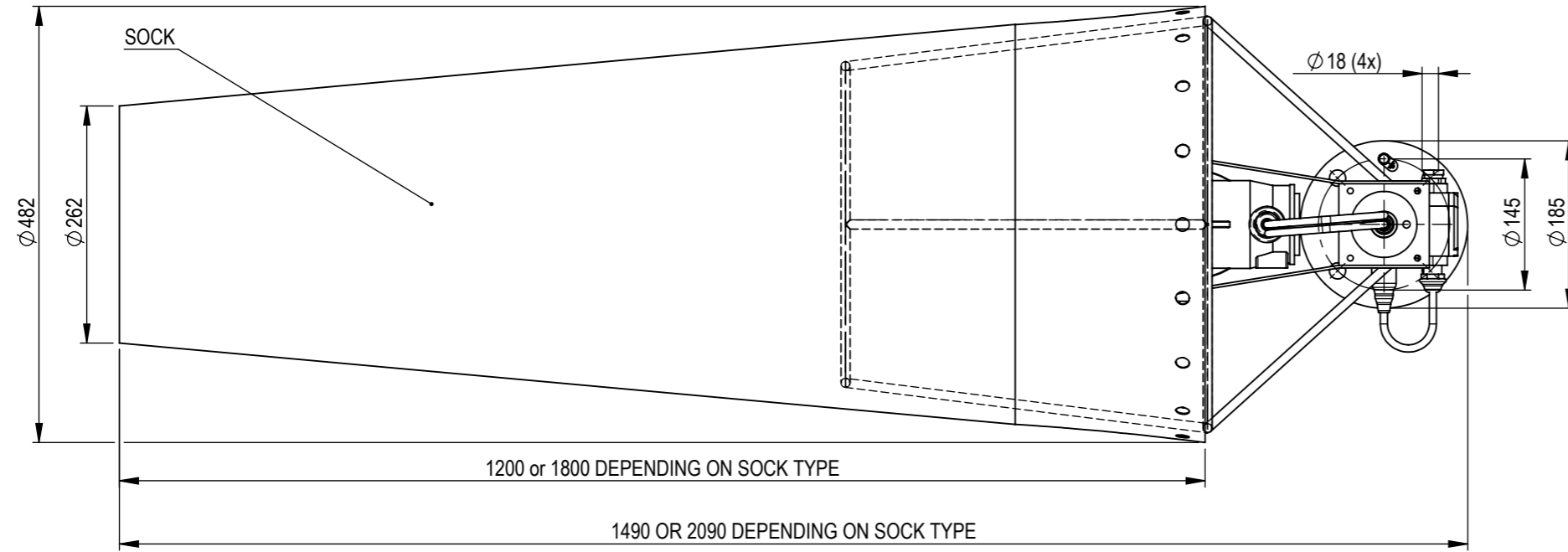

SPARE PARTS LIST			
PART NO	NAME	REFERENCE	DESCRIPTION
012340	Floodlight	HWC2000	
	HWC2000 Label	HWC2000	3M 7871E, ca. 46x36
see table	Sock	HWC2000	see table
010149	Reducer		REB - 0,75" NPT - M20
013010	A2F Gland		20/16-Metric
012423	8290 Blind plug		M20
	Shroud		type 'HV223'
	Shroud		type 'O' - on top of floodlight
012422	Lamp		120V, 15W

SOCK TYPE	DESCRIPTION	STOCK_NO
Orange	Orange, ca. 1200	012287
Orange-white	Orange-white, ca. 1200	012288
Red-white	Red-white, ca. 1200	010344
Red-white long	Red-white, ca. 1800	

LEFT VIEW

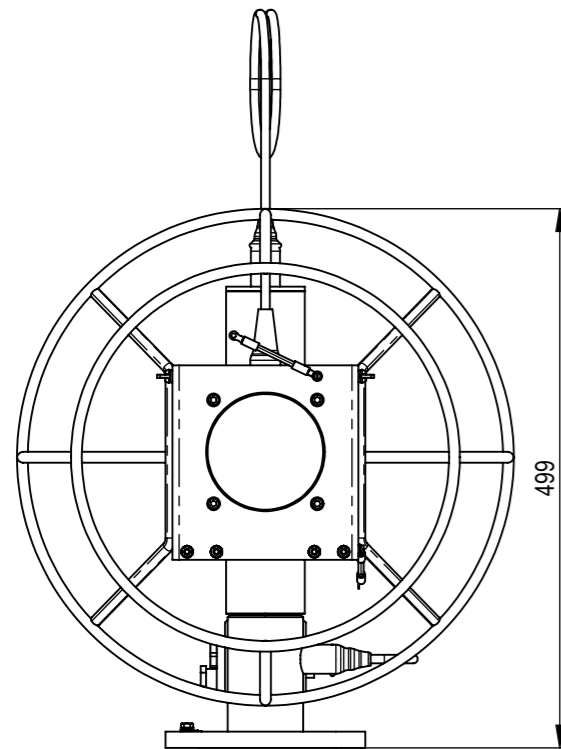

FRONT VIEW

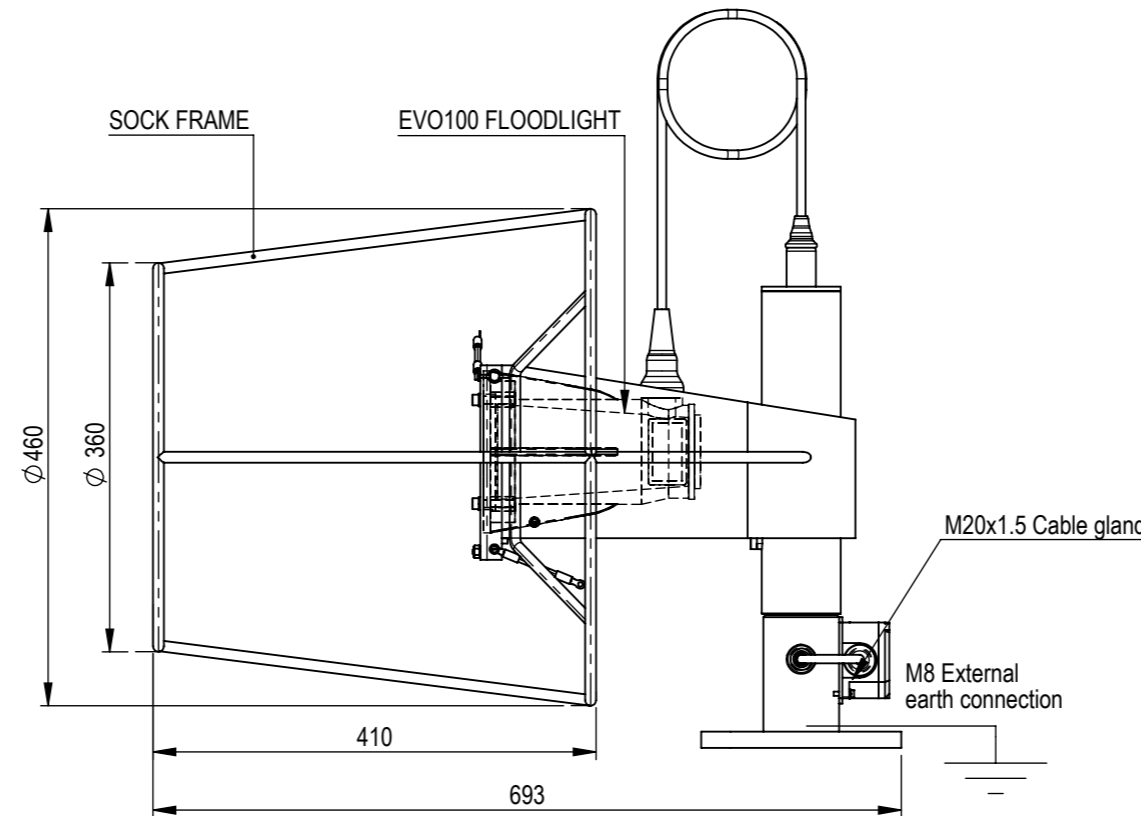

CLIENT CONNECTION

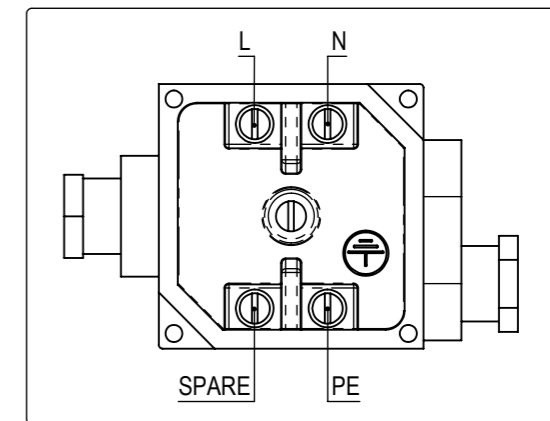

Note: all values are typical values

HWC2000EX-MKII-120	
Marking	: II 2G EEx d IIB T6
Certificate no.	: KEMA 02ATEX2060
IP rating	: IP66
Weight	: 22kg / 48.5lbs
Material	: Stainless steel

Rev.	Date	Drawn: AdB	Date: 12-10-2005	Client ref.:
0	12-10-2005	Checked:	Date:	
1	26-11-2007	Scale: 1:7		
2	29-12-2009	Sheet: 1 of 4		
3	31-03-2010	Arrangement drawing		All rights of design or invention are reserved
4	04-08-2010			

Windsock
TYPE: HWC2000EX-MKII-120

orga.
Strickledeweg 13
NL - 3125 AT SCHIEDAM
T +31 (0)10 208 5555
info@orga.nl
www.orga.nl

Project nr.: P5025
Drawing nr.: 5025- GA01