

### LEFT VIEW

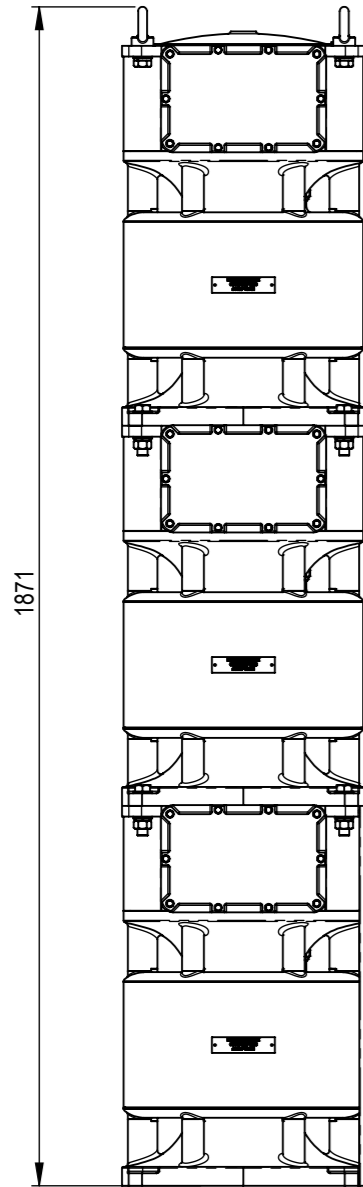

### FRONT VIEW

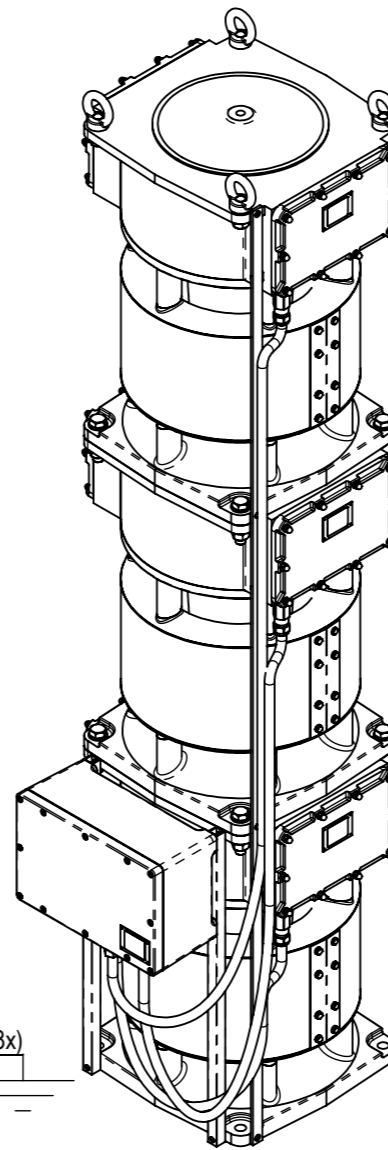
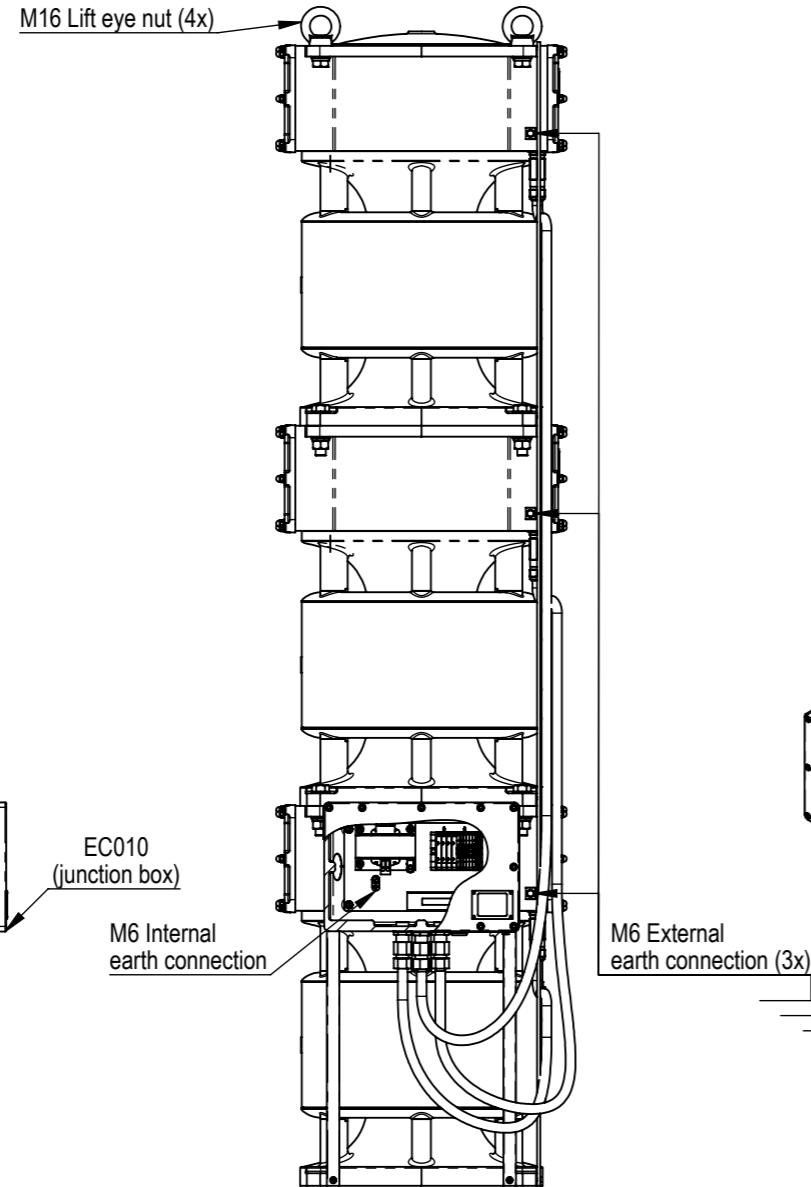

### SPARE PARTS LIST

| PART NO | NAME                      | REFERENCE | DESCRIPTION                          |
|---------|---------------------------|-----------|--------------------------------------|
| 011101  | Driver                    | FH800     |                                      |
| 010928  | Cover o-ring              | FH800     | Neoprene rubber, ca. ID218x Ø 6      |
| 010937  | Cilindrical cover         | FH800     | Plastic, ca. Ø 380x199               |
|         | Internals                 | FH800     | SS, 3 or 4 stack                     |
| 011600  | Transformer               |           | 100VA, 0-190V, 0-35-40-45V, 800-90Hz |
| 017145  | WAP2.5 end plate          |           |                                      |
| 012496  | WSI 6 fuse terminal       |           |                                      |
| 012491  | WDU2.5 terminal           |           |                                      |
| 015025  | WPE2.5 PE terminal        |           |                                      |
|         | WQV-2.5-4 Cross conection |           |                                      |
| 015212  | Fuse                      |           | 2A slow 5x20                         |
|         | Junction Box              | FH800     | Stainless steel, ca. 200x305x135     |
| 012133  | O-ring                    | EC010     | Rubber, ca. Ø 256x4                  |
| 014306  | Silicagel assembly        |           |                                      |

### CLIENT CONNECTION

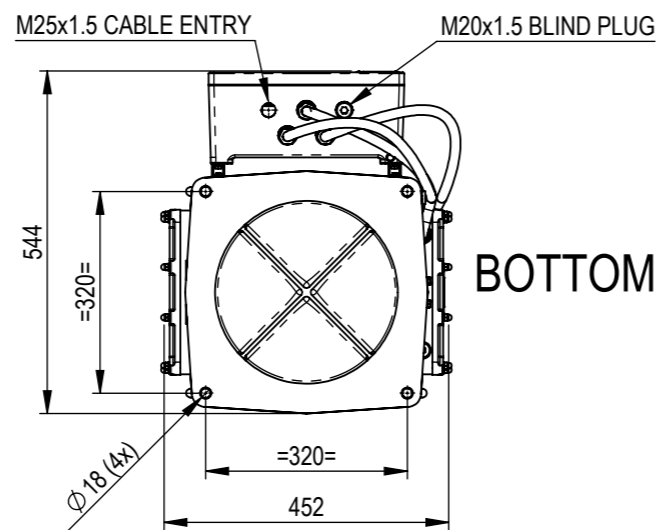
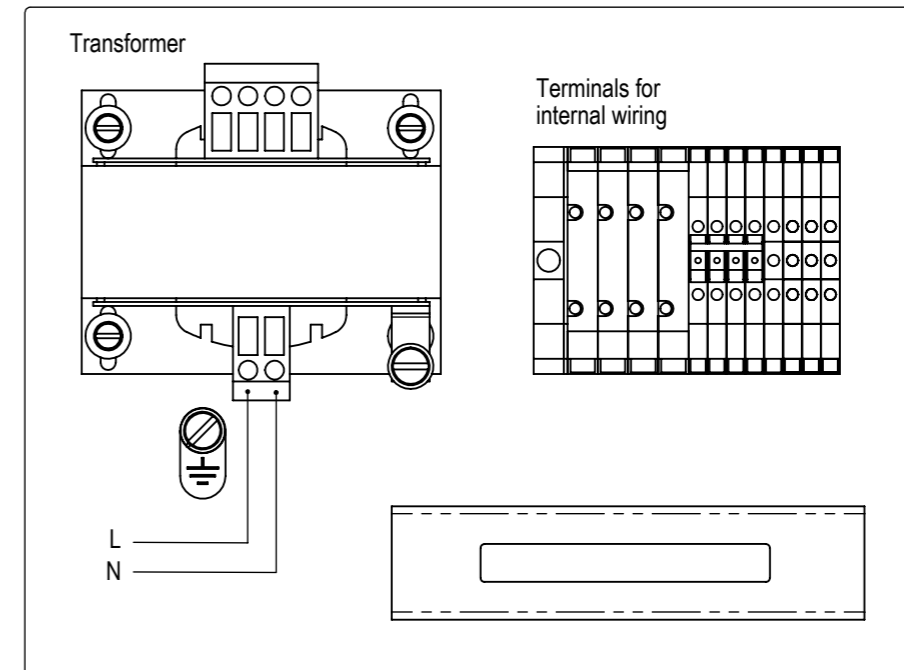

### BOTTOM VIEW

Note: all values are typical values

| EC010           |                      |
|-----------------|----------------------|
| Marking         | : II 2G EEx d IIB T6 |
| Certificate no. | : KEMA 05ATEX2049    |
| IP rating       | : IP65 (by design)   |
| Weight          | : 22kg / 48.5lbs     |
| Material        | : Stainless steel    |

| FH800(3)SA-SS   |                    |
|-----------------|--------------------|
| Marking         | : NA               |
| Certificate no. | : NA               |
| IP rating       | : IP66 (by design) |
| Weight          | : 360Kg / 793.7lbs |
| Material        | : Stainless steel  |

| Rev. | Date       | Drawn: EWB    | Date: 17-02-2010 | Client ref.: |
|------|------------|---------------|------------------|--------------|
| 0    | 17-02-2010 | Checked:      | Date:            |              |
| 1    | 04-08-2010 | Scale: 1:12   |                  |              |
| 2    |            | Sheet: 1 of 2 |                  |              |
| 3    |            |               |                  |              |
| 4    |            |               |                  |              |

Foghorn  
TYPE: FH800(3)SA-SS

**orga.**  
Strickledeweg 13  
NL - 3125 AT SCHIEDAM  
T +31 (0)10 208 5555  
info@orga.nl  
www.orga.nl

Project nr.: P5021  
Drawing nr.: 5021- GA31